

How to update T16IZ

Your Futaba T16IZ transmitter programming can be updated easily online. When functions are added or improved, the update file can be downloaded from our website. Copy the update files to the microSD card and then use the following procedure to update the program. Check our web site for the FAQ regarding updating for more information.

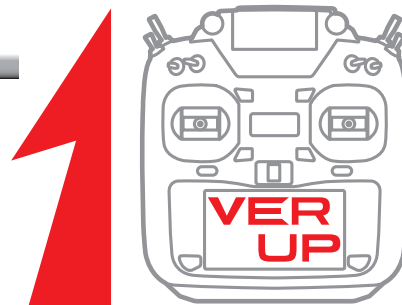

Updating procedure

Note: If the battery fully discharges during program updating, updating will fail. When the remaining battery capacity is 50% or less, always recharge the battery before updating.

Note: The model data in the transmitter can be used unchanged after updating, but to be safe, back up the model data before updating.

1. Download the zip file of the update data from our website.

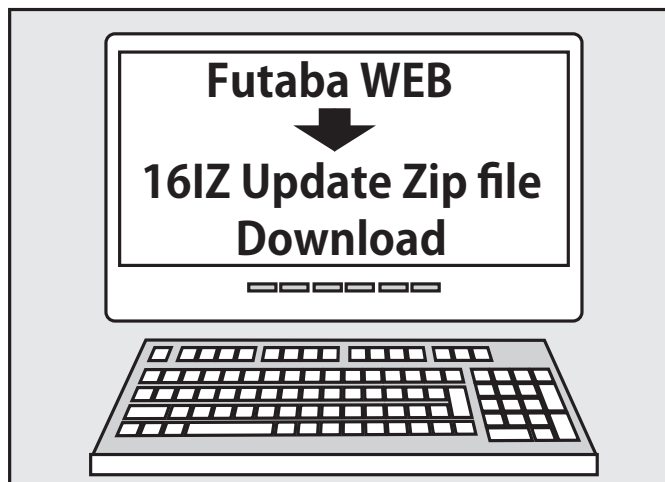

2. Extract the zip file on your computer.
3. The "FUTABA" folder will be created on your computer.
4. Copy the "FUTABA" folder into your microSD card.

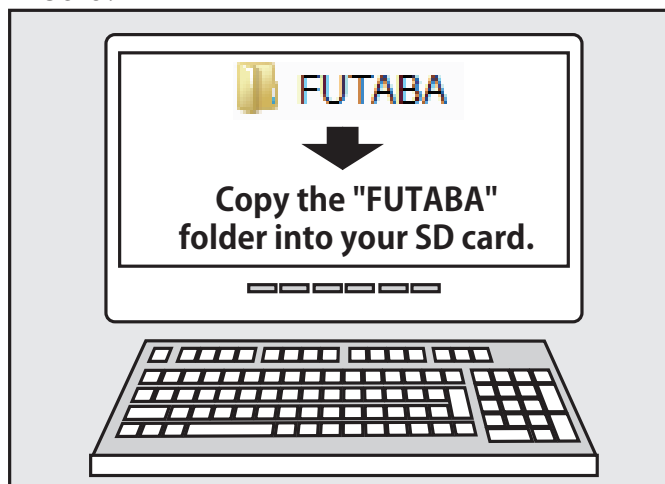

Note: If the microSD card has already had "another FUTABA" folder before you make a copy, the "FUTABA" folder is OVERWRITTEN.

5. Insert the microSD card with "FUTABA" folder that contained the update software into the SD card slot on your T16IZ radio transmitter.

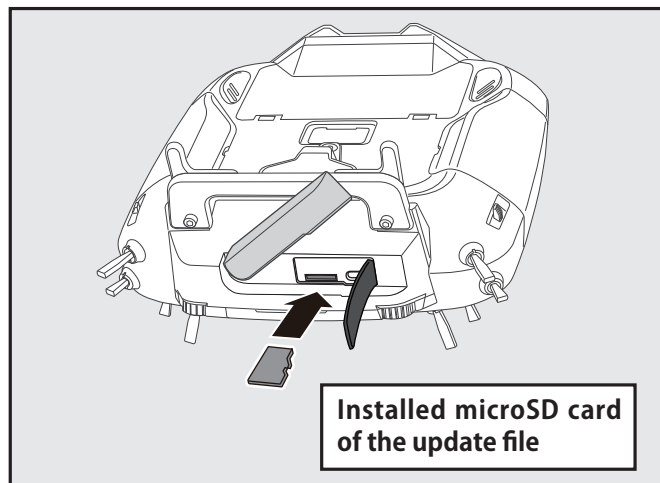

6. Turn on the transmitter power while pressing down the "HOME/EXIT" button. The update screen appears on the LCD display of your T16IZ and the software update is started.

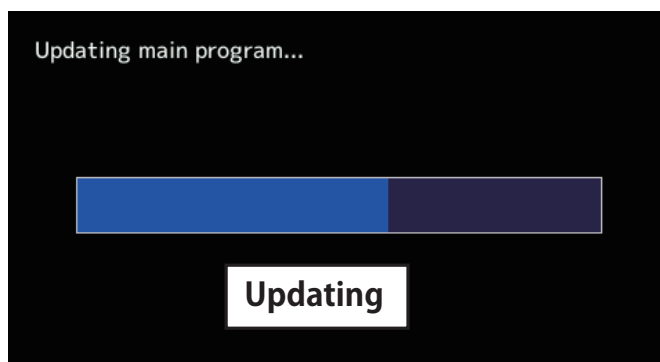
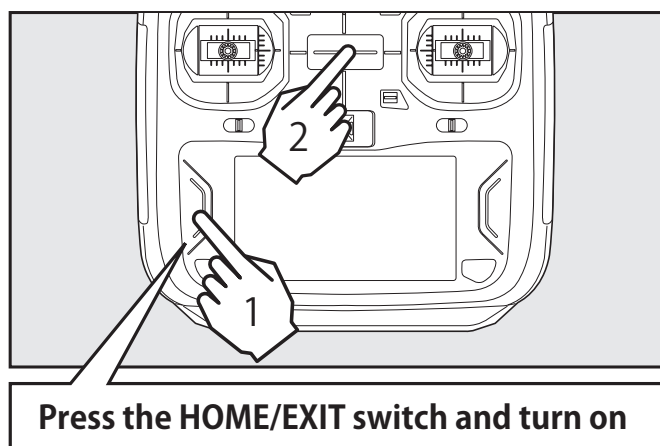

7. When the software update is completed, "Completed" message is shown on the LCD display of your T16IZ. (Show below picture.)

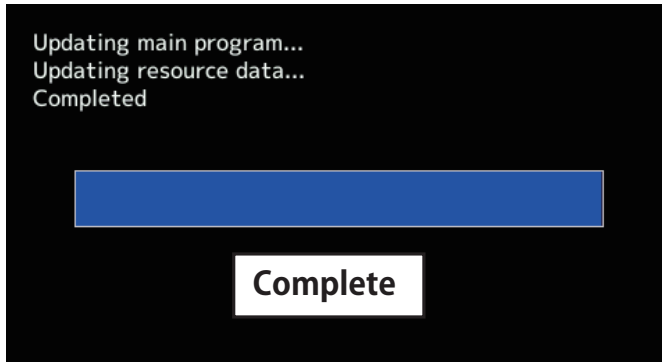

8. Turn off the power switch of your T16IZ and remove the microSD card from the card slot.

Possible Problems

When one of the error messages shown below appears on the LCD screen your T16IZ, the software update will not be completed.

"Low battery."

Software update is postponed because of low battery. Retry the software update after the battery is recharged.

"Update file not found."

The T16IZ cannot find the update file on the microSD card. Check to be sure all the update files have been copied onto the microSD card.

"Broken file."

The T16IZ detects the update file error. The update file may be broken or for another transmitter.

"Write error."

The software update procedure is stopped for an unknown reason. Contact your local service center when this error message appears on the LCD screen of your T16IZ.



Don't absolutely remove the battery and the microSD card from the transmitter during the update.

There is a possibility that the transmitter will be damaged.

Recovering a failed update

If you failed to update for any reason, it may transmitter will not start.

In that case, please update again transmitter in the following procedure.

1. Detach the battery from the transmitter.
2. Insert the microSD card that contained the update files to the transmitter.
3. Attach the battery to the transmitter while pressing down the "HOME/EXIT" button.
4. The update will start.

Even after the above steps, if the transmitter fails to update or does not start, please have it serviced.

T16IZ SOFTWARE UPDATE CHANGES

V8.0

This software updates or alters the functions and features noted below. The instructions and information that follow are meant as a supplement to the original instruction manual that accompanied the T16IZ transmitter. Please refer to the original instruction manual where applicable, but replace the steps indicated below with these instructions. Please check to ensure that the update has been installed.

- 1) Select the System Menu.
- 2) Touch the [Information] button.
- 3) Confirm that the information in the display indicates the version numbers as noted above.

1. GYA553 New firmware Version 4.x support. → Refer to T16IZ/T16IZ SUPER GYA553 V4 Setting manual

2. Some of the audio for “Sound Select” has been revised.

V7.0

1. CGY770R support. → Refer to T16IZ/T16IZ SUPER CGY770R Setting manual

2. Added confirmation dialog for group setting button of condition

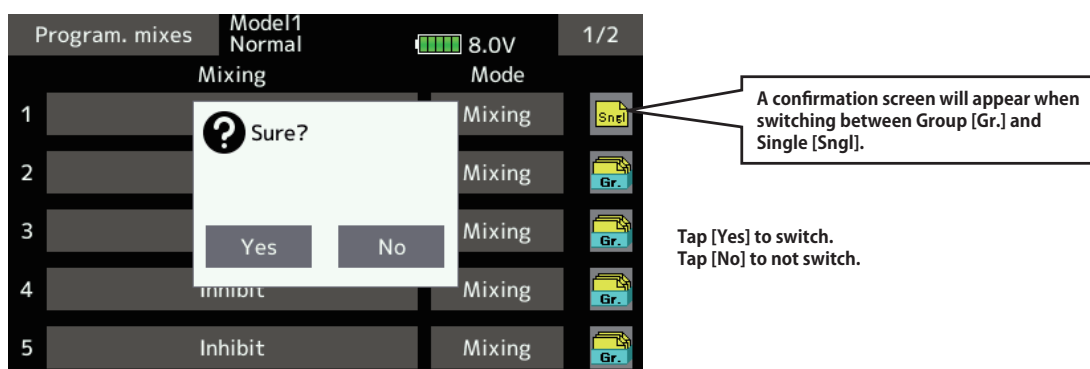

3. Added power off confirmation function

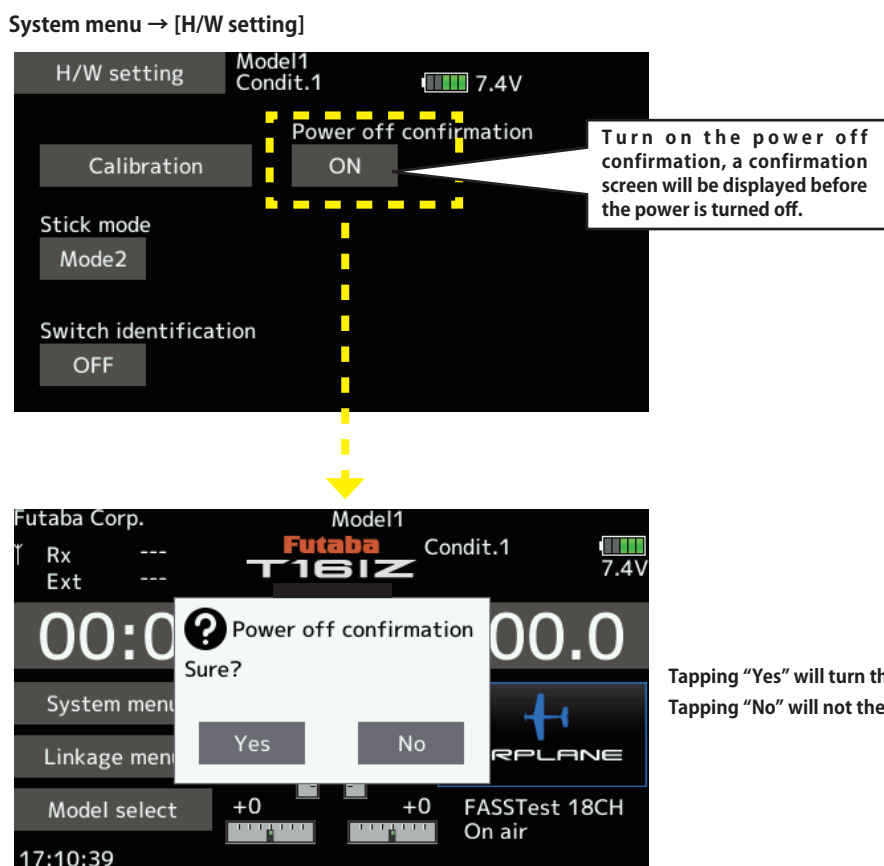

1. Receiver setting : It is now possible to connect a compatible receiver to the S.I/F port of the transmitter and configure the receiver settings.

Compatible receivers are as follows. (As of January 2024)

- R7208SB/R7308SB (Compatible with software version 2.0 or later)
- R7206SB/R7306SB
- R7214SB/R7314SB

① Connect the **S.BUS2 port** of the receiver and the **S.I/F port** of the transmitter with a cable.

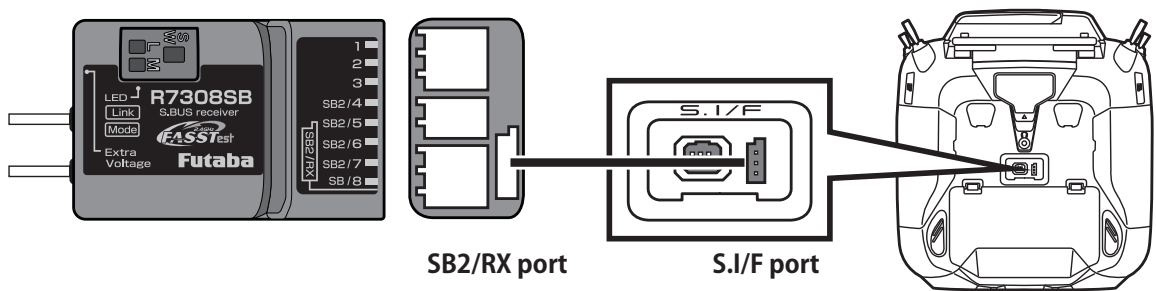

② Turn on the power switch while pressing the **U.MENU/MON** button on the transmitter.

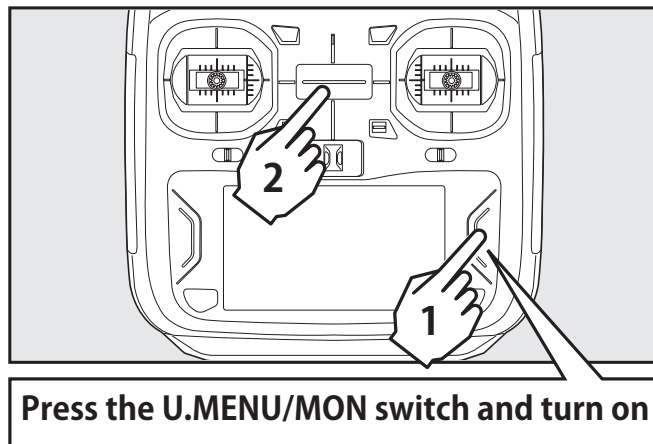

*For safety reasons, receiver settings cannot be made while radio waves are being transmitted.

③ Tap **[Receiver setting]** on the **System menu**.

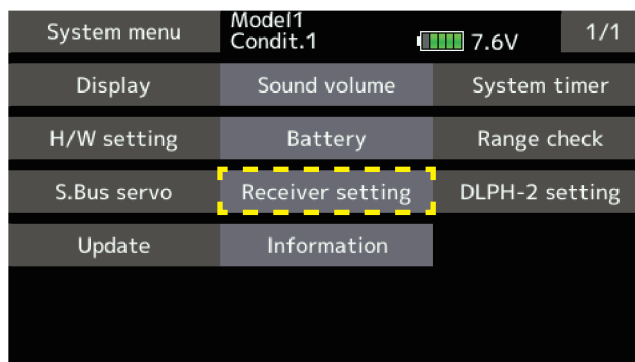

④ Tap [Read].

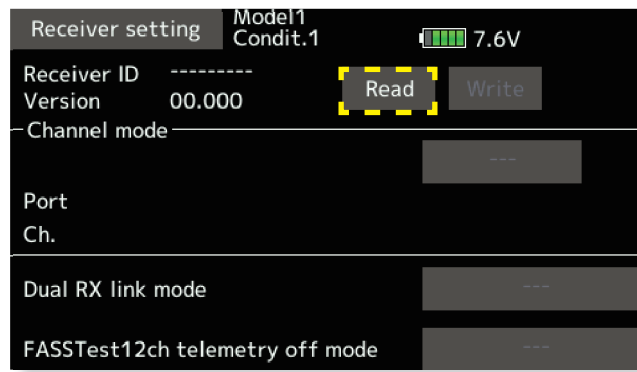

⑤ The receiver settings will be displayed. The displayed contents vary depending on the model.

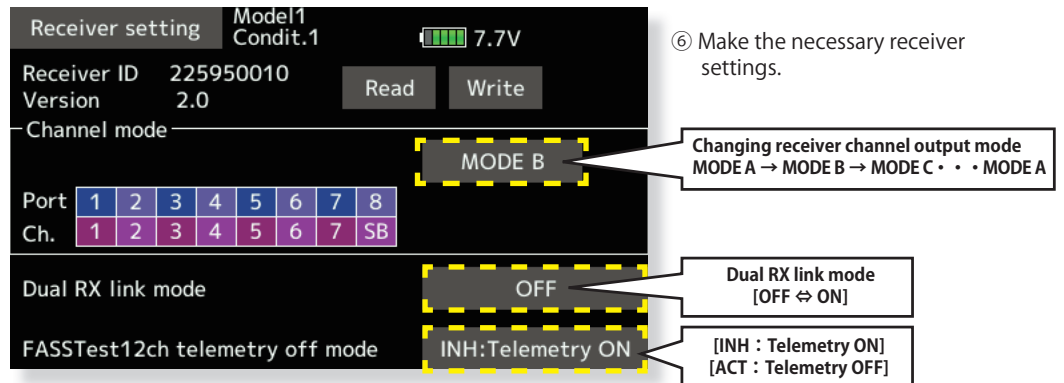

⑦ Tap [Write]. → Receiver settings will be changed.

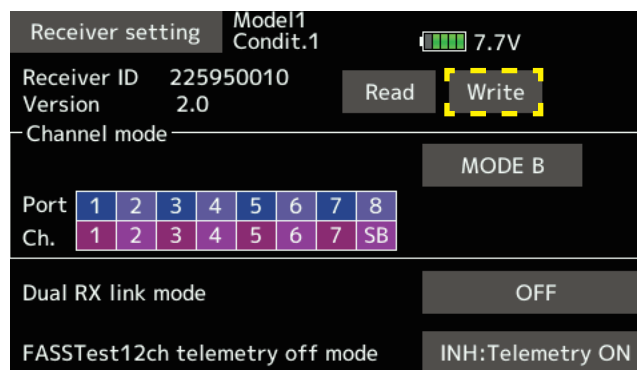

*T16IZ cannot operate after 17ch.

⑧ Remove the receiver from the transmitter.

2. DLPH-2 setting : It is now possible to connect a DLPH-2 to the S.I/F port of the transmitter and configure the DLPH-2 settings.

- ① Connect the power supply to the BAT.1 or BAT.2 port of DLPH-2.
- ② Connect the **RX1 port** of the DLPH-2 and the **S.I/F port** of the transmitter with a cable.

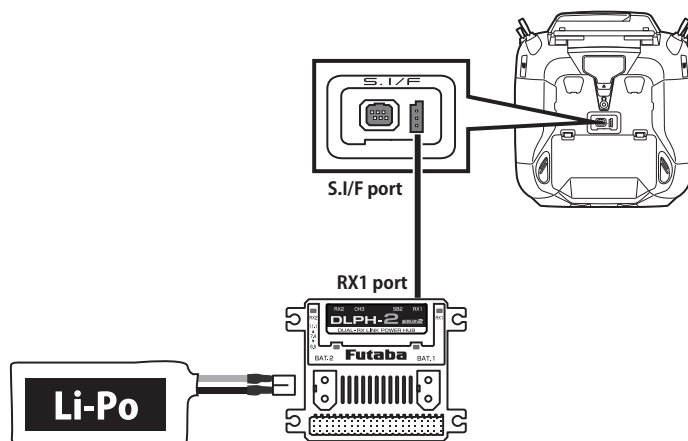

- ③ Turn on the power switch of DLPH-2.
- ④ Tap **[DLPH-2 setting]** on the **System menu**.

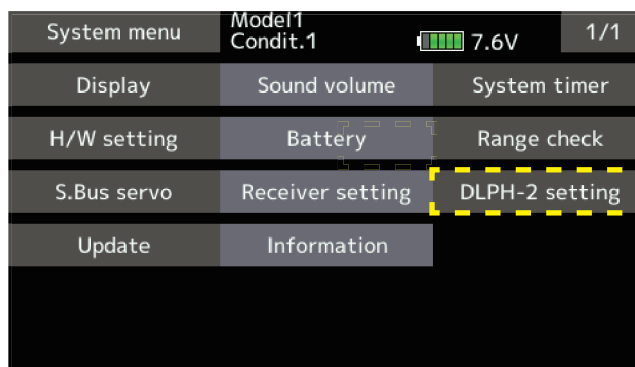

- ⑤ Tap **[Read]**.

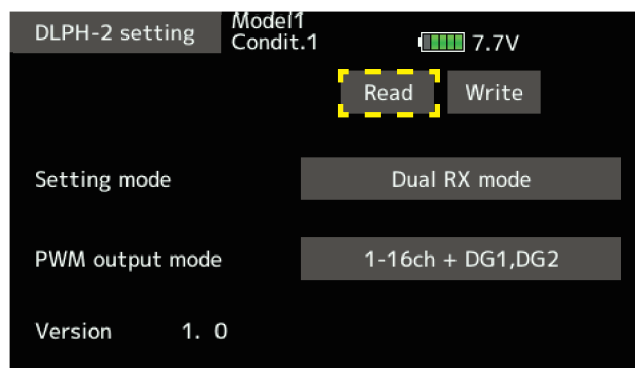

- ⑥ The DLPH-2 settings will be displayed.

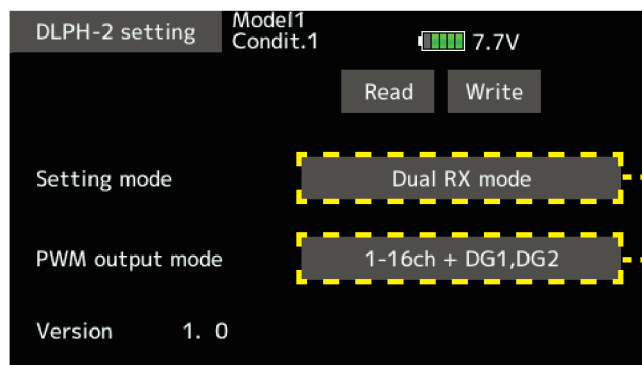

- ⑦ Configure the DLPH-2.

Dual RX mode → Single RX mode → Airplane gyro mode → Dual RX mode → ...

1-16CH + DG1,DG2 → 17-24CH + DG1,DG2 → 1-16CH + DG1,DG2 → ...

Mode selection

*When setting mode is set to **[Airplane gyro mode]**, PWM output mode is fixed to **[1-16CH + DG1,DG2]**.

*T16IZ cannot operate after 17ch.

⑧ Tap **[Write]**. → DLPH-2 settings will be changed.

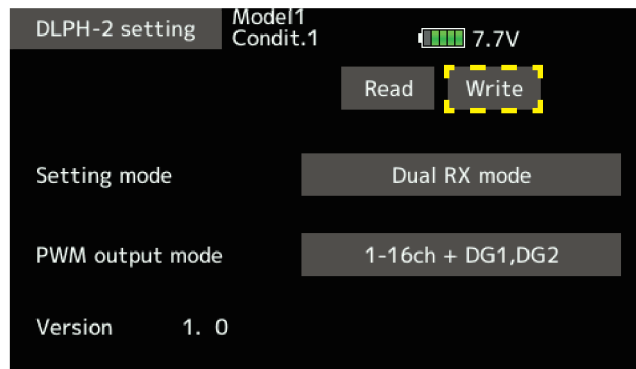

⑨ Remove DLPH-2 from the transmitter.

3. Added switch identification function : On the hardware selection screen, operate the desired toggle switch and it will be automatically selected.

① Tap **[H/W setting]** on the **System menu**.

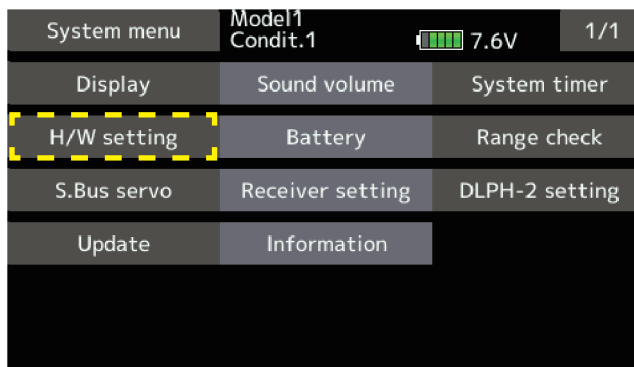

② Setting **[Switch identification]** to **[ON]** enables the switch identification function. Set to **[OFF]** to disable the switch identification function.

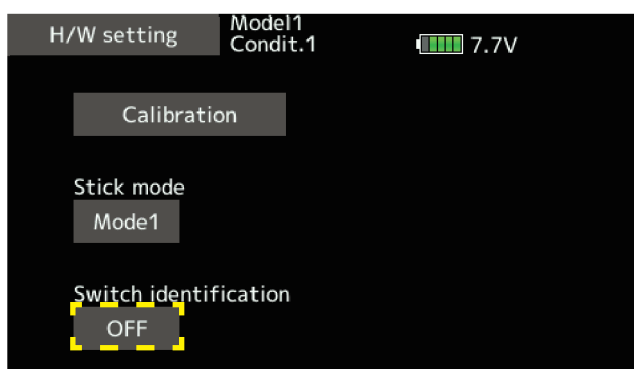

③ Call the **[Hardware select]** screen from the settings screen for each function.

④ Operate the toggle switch (either **SA to SH**) to assign.

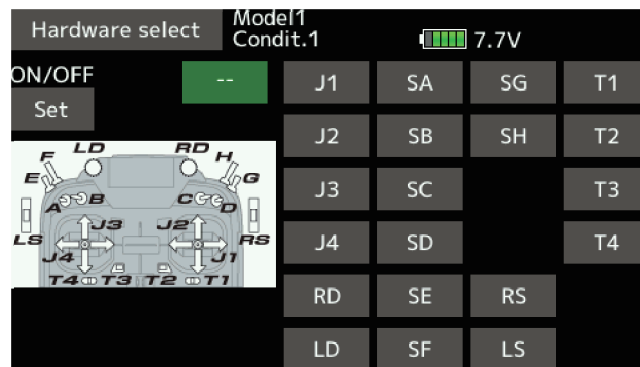
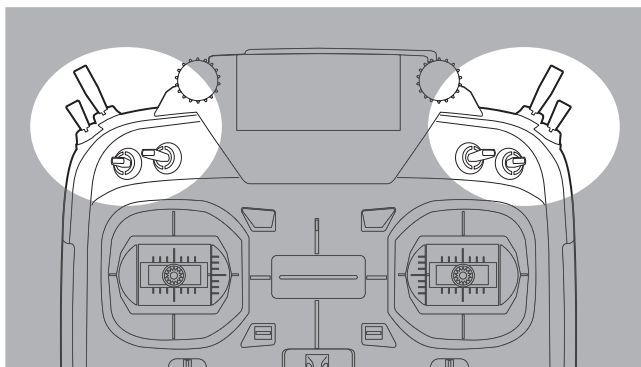

⑤ The operated switch is selected. Sets the current switch position to **ON**. Operating the switch changes the **ON** position.

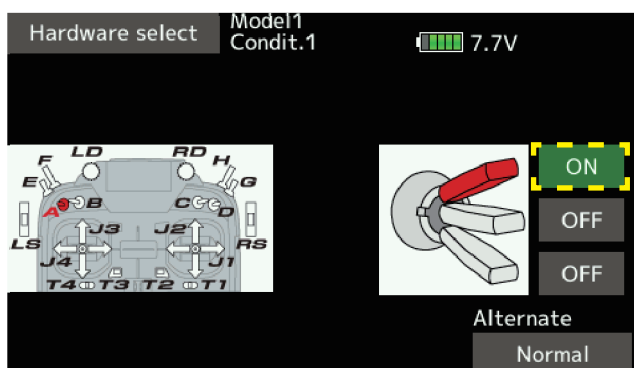

1. Switch Sounds : The Sound select function adds sounds to switch positions.

(Only English sounds are supported.)

- Tap the [Sound Select] button in the linkage menu to call the setup screen shown at the right.
- Take notice of the SW Letter and position
- Tap the desired switch position.

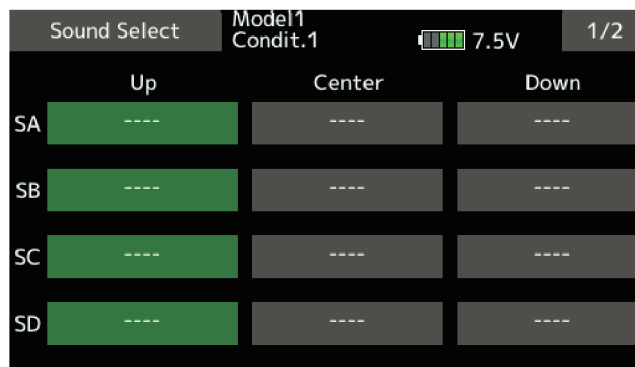

- Tap on the desired sound to add the requested sound in the previously selected switch position. (It will demo the sound once pressed)

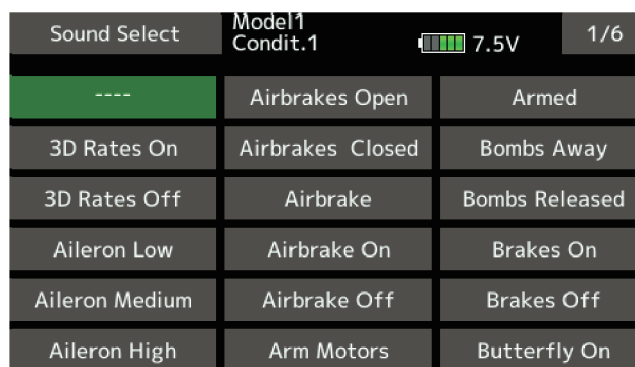

NOTE: Sounds and switch positions do not acknowledge condition priority.

Sounds are intended as a reference for changes in flight profile and will need to be changed manually if programming deviates from previous setup.

2. Sound notification: It is possible to notify the operating status of the transmitter by voice, such as ON/OFF of various mixing functions.

(Only English sounds are supported.)

- Tap the [Warning Setting] button in the linkage menu to call up the warning settings screen.
- Display the second page and call up the settings screen below.

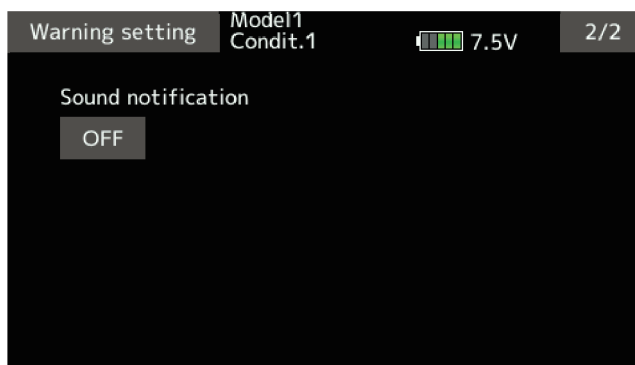

- Tap the [Sound notification] setting button to turn the sound notification function ON/OFF.
- If you set the sound notification function to ON, you will be notified by voice when the ON/OFF status or condition of various mixing functions changes.

NOTE: Condition audio notifications use standard condition names. Please note that if you change the condition name or rearrange the priority order, the audio notification and display will no longer match.

3. Telemetry settings: Added gear ratio setting button to Kontronik ESC and Scorpion ESC.



● If the gear is down, enter the gear ratio to display the helicopter rotor speed and the airplane gear down propeller speed.

4. Telemetry settings: Changed the motor pole number setting for each ESC to "100".

Previously, the number of poles was up to 36, but now it can be set up to 100.

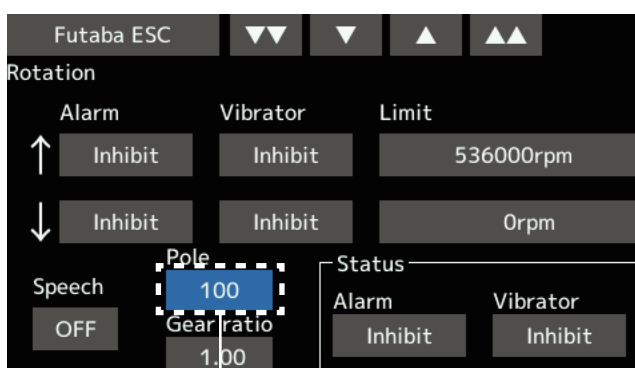

● Enter the number of poles for your motor.

1. Receiver or gyro updates

By connecting a receiver or gyro that supports updates to the S.I/F connector of the transmitter, it is possible to update their software.

- ① Download the update file of the update data from Futaba website.
- ② Extract the update file on your computer. The "FUTABA" folder will be created on your computer.
- ③ Copy the "FUTABA" folder into your microSD card.
- ④ Insert the microSD card with "FUTABA" folder that contained the update software into the SD card slot on your transmitter.
- ⑤ Turn on the transmitter and call "System Menu" ⇒ "Update".

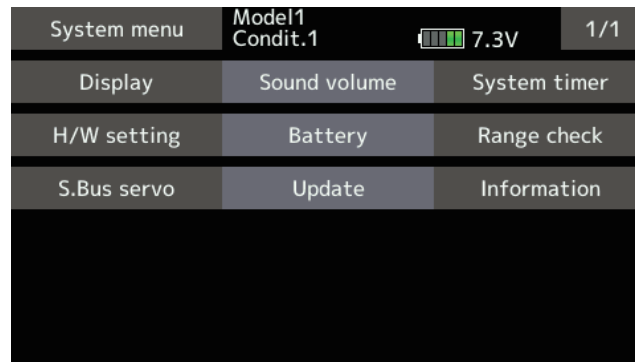

- ⑥ Select the product to update.

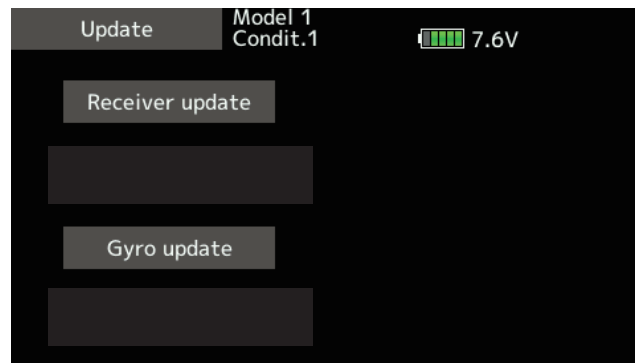

- ⑦ Select the product name to update.

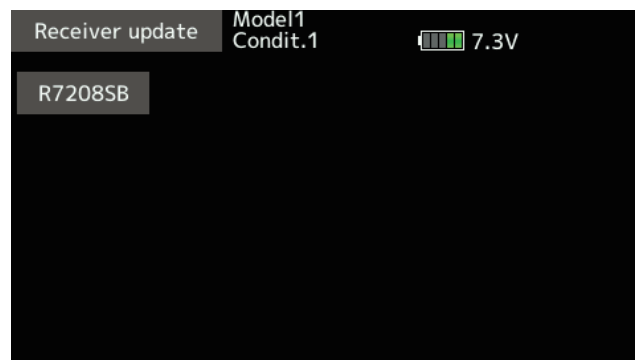

- ⑧ The update screen is displayed. Connect the receiver or gyro to be updated to the S.I/F connector of the transmitter, prepare for update, and then tap the [Update] button.

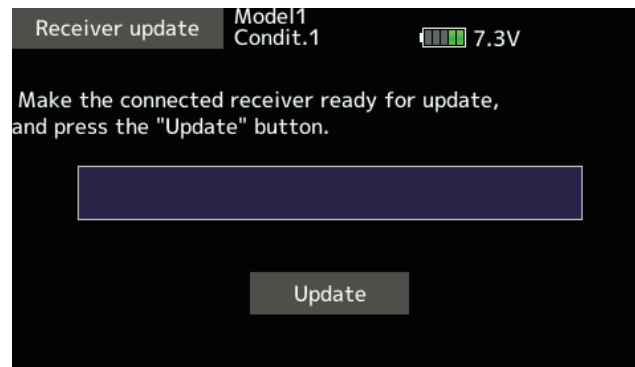

- ⑨ Update start.

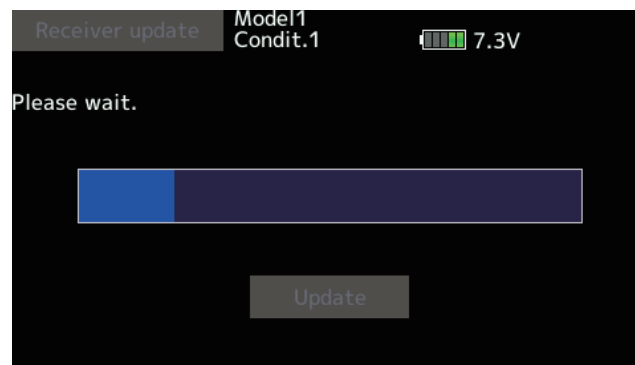

- ⑩ When finished, the following will appear.

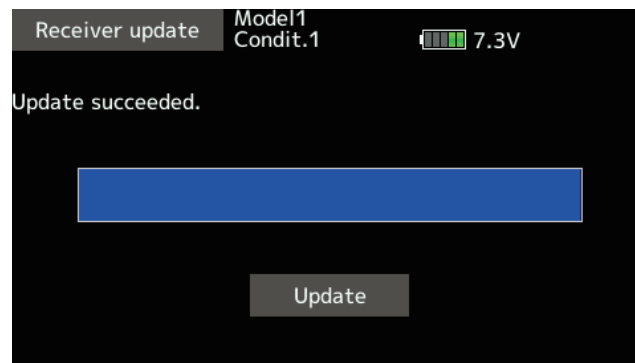

- ⑪ Disconnect the receiver or gyro from the transmitter's S.I/F connector.

V3.4

1. GYA553 New firmware Version 3.x support. → Refer to T16IZ/T16IZS GYA553 V3 Setting manual

Airplane Gyro GYA553 is compatible with 3rd aileron and 4th aileron.

1. GYA553 New firmware Version 2.x support. → Refer to T16IZ GYA553 V2 Setting manual

1. CH3 (THR) can be output to the RUD2 / S.BUS2 port.
2. The Holding Power rate of the aircraft in AVCS mode has been expanded to 5 types from C1 to C5, and each rate can be set by switching the display.
3. Added the setting of switching CH of Holding Power rate C1 to C5 to S.BUS basic menu.

◆ Basic Menu screen

The software version of the connected GYA553 is displayed.

Tap to the basic menu

◆ Config screen

There are 7 pages in total, and the additional functions are 1 page and 6 pages.

Added CH3 (THR) to the output item of RUD2 / S.BUS port

◆ S.BUS Basic screen

To "Config"

To "SBUS Basic"

C1-C5 switch button

With the switch button, the "holding power" of each rate (C1 to C5) can be displayed and adjusted.

◆ S.BUS Basic screen The second page has been added, and the total number of pages has changed from 2 to 3.

Additional page

Tap to move to the rate switching CH setting page.

Holding Power C2 to C5

Condition

Tap the CH used for rate switching to select it.

CH1	CH5	CH9	CH13	DG1
CH2	CH6	CH10	CH14	DG2
CH3	CH7	CH11	CH15	INH
CH4	CH8	CH12	CH16	

The current rate numbers C1 to C5 are displayed by operating the channel of the transmitter.

Like the flight condition function of the transmitter, you can set up to 5 different data for the attitude holding force rate of the aircraft in AVCS mode by operating the switch from the transmitter, and switch between them. You can set the holding power rate selector switch to the channel with the AFR function of the transmitter, and set the point for each rate on the AFR point curve to switch. It is also possible to use the flight condition function to work with the flight condition switch.

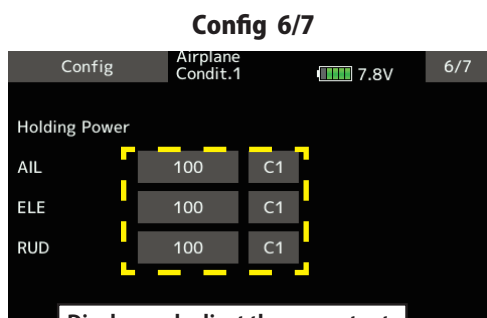

Display and adjust the current rate numbers C1 to C5 by operating the channel on the transmitter.

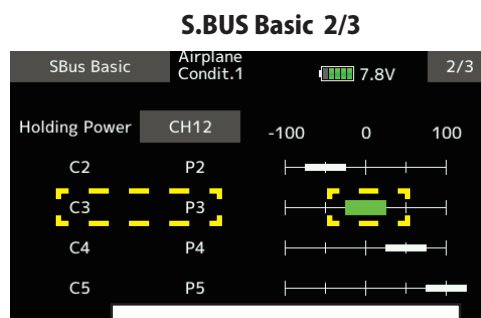

By operating the channel of the transmitter, the channel position of the current rate numbers C1 to C5 will be displayed in green.

When set to SW of DG1 or DG2

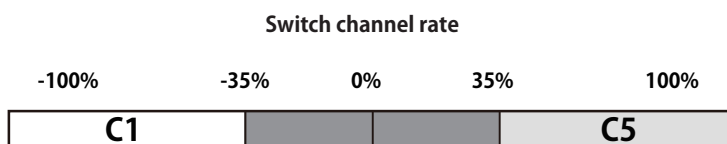
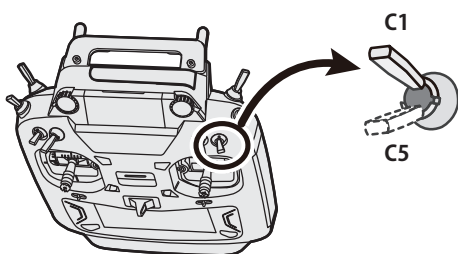

When set to dial or lever

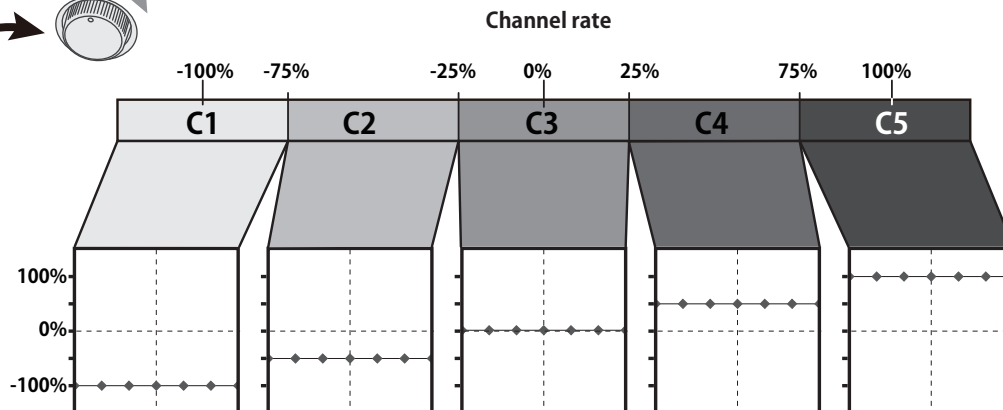
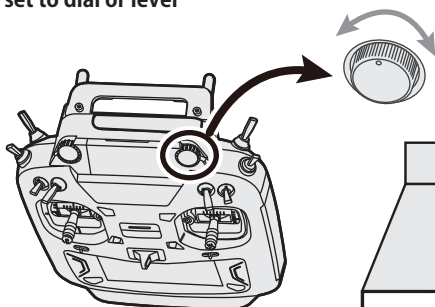

2. O.S.ENGINE EM-100 New firmware Version 9.11 support.

If you have used the EM-100, the update will unregister the EM-100 from the "Sensor" screen. Register the EM-100 again on the "Sensor" screen.

V3.2

1. Fixed an issue where the Vario Melody settings were not saved.

V3.1

1. Fixed telemetry voice for Futaba ESC and Hobbywing ESC.
2. Fixed the problem that model copy fails.

V3

1. Compatible with Futaba ESC MC-980H/A, MC-9130H/A, MC-9200H/A

Supports the telemetry function of MC-980H/A, MC-9130H/A, and MC-9200H/A.

- ◆ Register the ESC with transmitter.

- ◆ Alternatively, select [Futaba ESC] in start slot 24.

Registration to transmitter

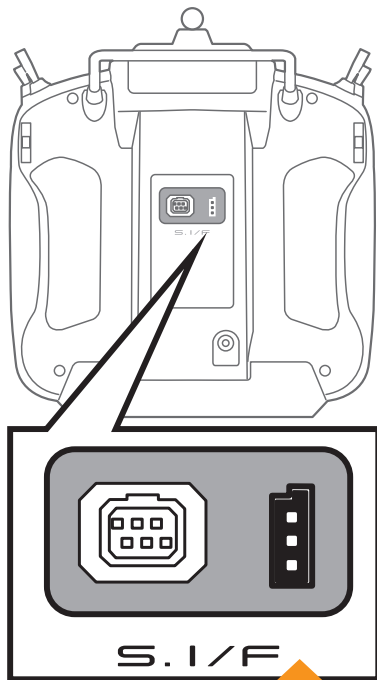

Connect SBM-2 to the S.I/F port on the back of transmitter.

- ◆ Linkage menu → Sensor → 3/3

- Call page 3 of [Sensor].

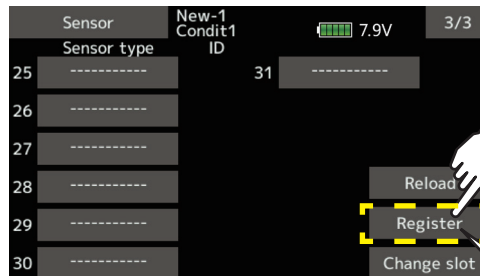

Connect the SBM-2 to the transmitter as shown, then tap Register.

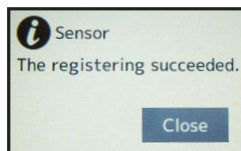

Registration is complete when this screen appears

Complete registration and remove SBM-2 from the transmitter.

*Please note that the proper default slot for this accessory is number 8 (8-15). This sensor uses eight slots. Being made to a start slot are 8, 16, and 24. Information on how to change the slot assignment is included in the transmitter's manual.

- ◆ The registered ESC will be displayed as "Futaba ESC".

- ◆ The registered Hobbywing ESC is displayed as "Hobbywing ESC".

For details on Hobbywing ESC telemetry support, refer to the Hobbywing website.

◆ MC-9130H / A telemetry connection example

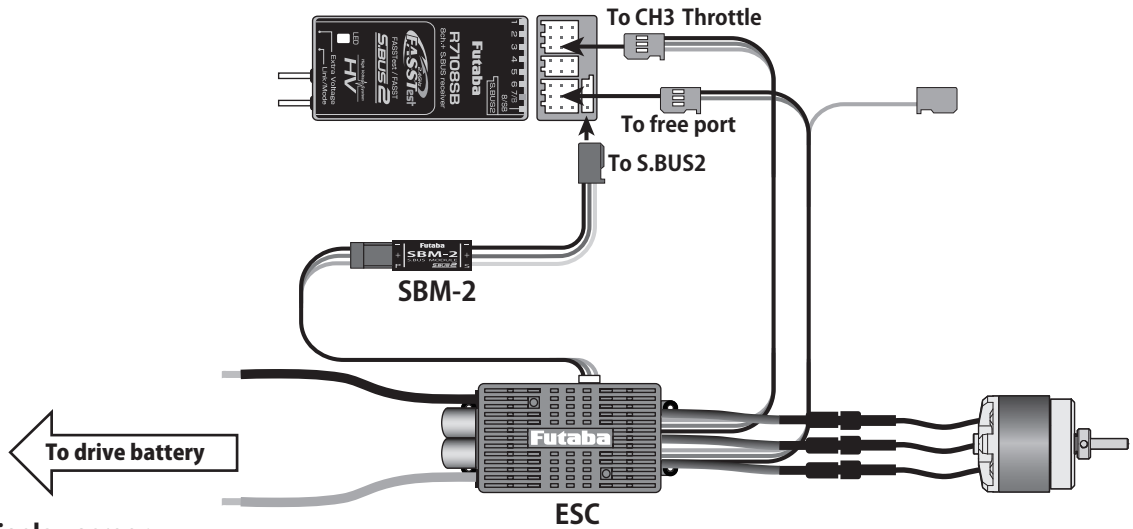

◆ ESC telemetry display screen

The ESC status is displayed. Alarm setting is also possible.

Tap to move to the current setting page.

Tap to move to the voltage setting page.

Tap to move to the capacity setting page.

Tap to move to the rotation setting page.

Tap to move to the temperature setting page.

Display max / min value Press and hold to reset.

Display max / min value Press and hold to reset.

Shows the output level from the ESC to the motor, not the position of the throttle stick. Even if the stick is in the 50% position, the output may not be 50% depending on the ESC setting. Tap to move to the throttle setting page.

◆ Alarm setting

↑ An upward arrow indicates the alarm will sound when the current reaches above your set value.

↓ A downward arrow indicates the alarm will sound when the current reaches below your set value.

Allows Speech to be turned ON or OFF.

Alarm is chosen from Buzzer, Voice, and Inhibit.

Sets the current on which the alarm operates.

Display max / min value Press and hold to reset.

*The current and capacity consumption display may vary depending on the usage conditions, so use it as a guide.

◆ Alarms can be set for Voltage, Capacity, Rotation, ESC temperature, and Throttle using the same procedure.

Enter the number of poles for your motor.

If the gear is down, enter the gear ratio to display the helicopter rotor speed and the airplane gear down propeller speed.

When enabled, the alarm will be activated in the following warning state.

When enabled, the vibrator will start in the following warning state.

◆ Warning state

Throttle not at 0%	When the throttle stick is not low when ESC is started
Low voltage	When the battery voltage is below the cutoff voltage
Over temperature	When the ESC temperature is 110 °C or higher
Over current	Peak current over
Motor locked	When the motor locks
Throttle signal lost	When no throttle signal is received for more than 0.25 s

2. GYA553 Addition of setting parameters

AIL / ELE / RUD holding power setting has been added to the setting parameters of GYA553.

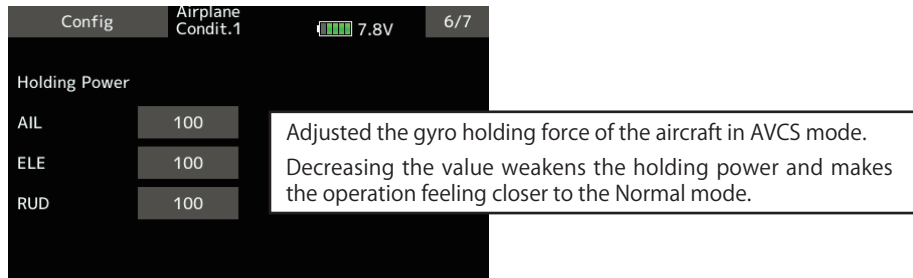

V2

1. Add GYA553 Airplane Gyro setting function. (Refer the T16IZ GYA553 Setting Manual)

2. Compatible with SCORPION ESC telemetry

Added support for SCORPION POWER SYSTEM ESC some models.