

# How to update T16IZ SUPER

Your Futaba T16IZ SUPER transmitter programming can be updated easily online. When functions are added or improved, the update file can be downloaded from our website. Copy the update files to the microSD card and then use the following procedure to update the program. Check our web site for the FAQ regarding updating for more information.

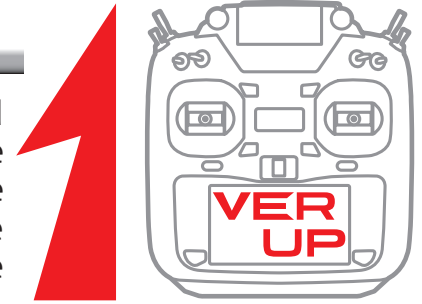

## Updating procedure

Note: If the battery fully discharges during program updating, updating will fail. When the remaining battery capacity is 50% or less, always recharge the battery before updating.

Note: The model data in the transmitter can be used unchanged after updating, but to be safe, back up the model data before updating.

1. Download the zip file of the update data from our website.

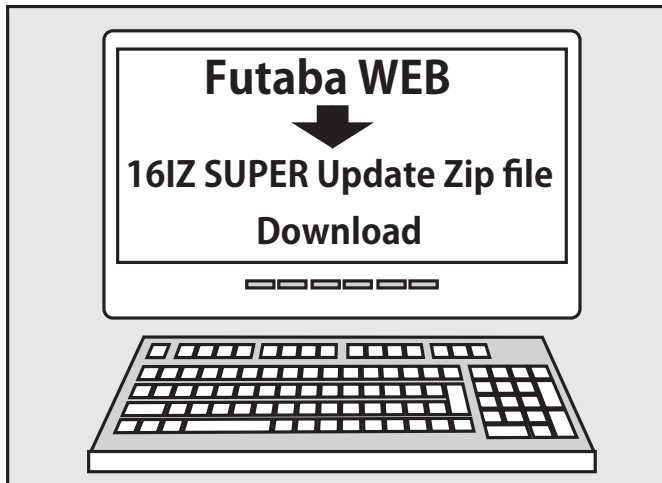

2. Extract the zip file on your computer.
3. The "FUTABA" folder will be created on your computer.
4. Copy the "FUTABA" folder into your microSD card.

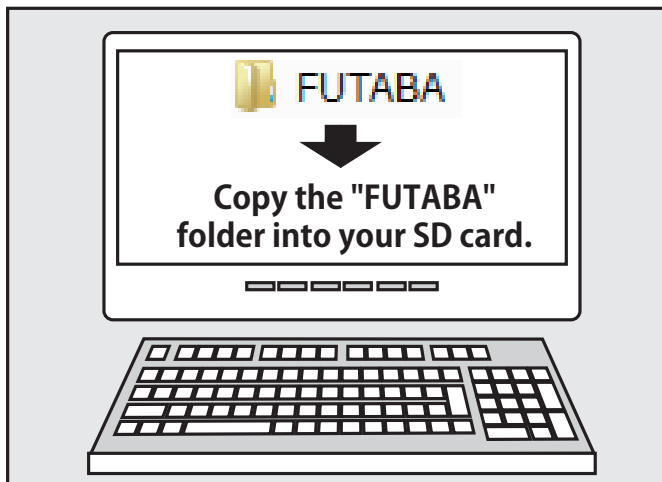

Note: If the microSD card has already had "another FUTABA" folder before you make a copy, the "FUTABA" folder is OVERWRITTEN.

5. Insert the microSD card with "FUTABA" folder that contained the update software into the SD card slot on your T16IZ SUPER radio transmitter.

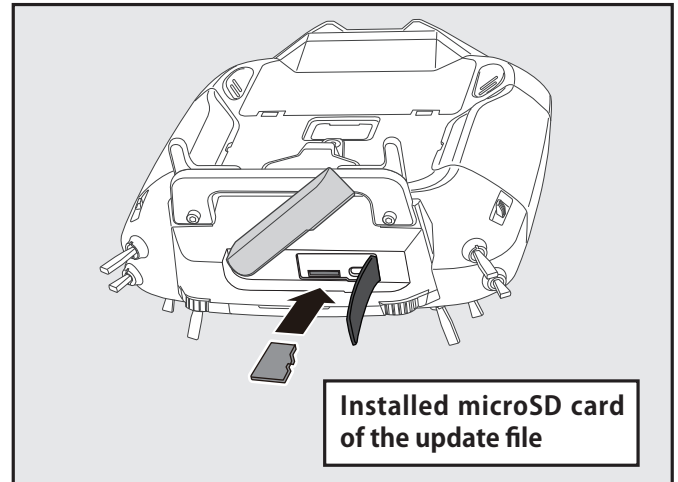

6. Turn on the transmitter power while pressing down the "HOME/EXIT" button. The update screen appears on the LCD display of your T16IZ SUPER and the software update is started.

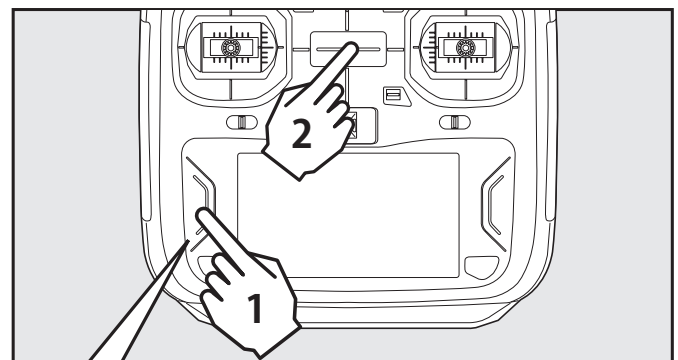

Press the HOME/EXIT switch and turn on

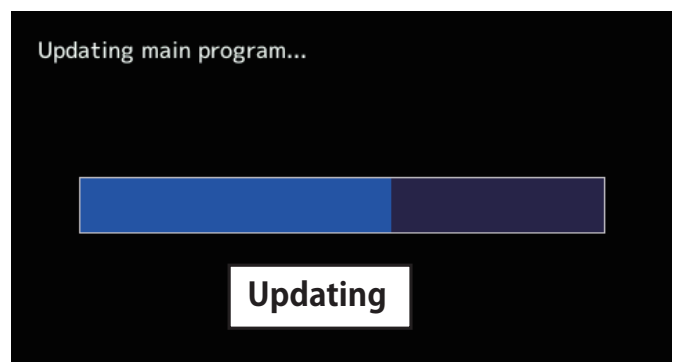

7. When the software update is completed, "Completed" message is shown on the LCD display of your T16IZ SUPER. (Show below picture.)

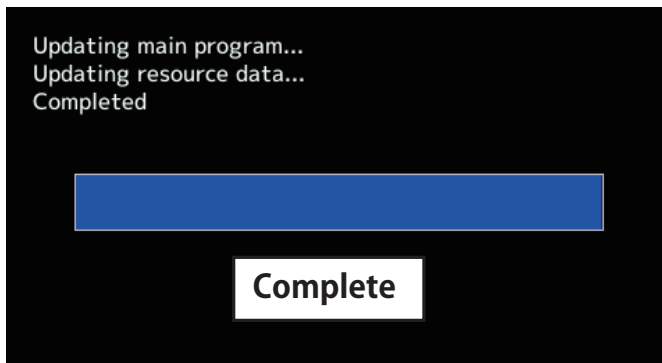

8. Turn off the power switch of your T16IZ SUPER and remove the microSD card from the card slot.

### **Possible Problems**

When one of the error messages shown below appears on the LCD screen your T16IZ SUPER, the software update will not be completed.

"Low battery."

Software update is postponed because of low battery. Retry the software update after the battery is recharged.

"Update file not found."

The T16IZ SUPER cannot find the update file on the microSD card. Check to be sure all the update files have been copied onto the microSD card.

"Broken file."

The T16IZ SUPER detects the update file error. The update file may be broken or for another transmitter.

"Write error."

The software update procedure is stopped for an unknown reason. Contact your local service center when this error message appears on the LCD screen of your T16IZ SUPER.



Don't absolutely remove the battery and the microSD card from the transmitter during the update.

There is a possibility that the transmitter will be damaged.

Recovering a failed update

If you failed to update for any reason, it may transmitter will not start.

In that case, please update again transmitter in the following procedure.

1. Detach the battery from the transmitter.
2. Insert the microSD card that contained the update files to the transmitter.
3. Attach the battery to the transmitter while pressing down the "HOME/EXIT" button.
4. The update will start.

Even after the above steps, if the transmitter fails to update or does not start, please have it serviced.

# T16IZ SUPER SOFTWARE UPDATE CHANGES

## V6.0

This software updates or alters the functions and features noted below. The instructions and information that follow are meant as a supplement to the original instruction manual that accompanied the T16IZS transmitter. Please refer to the original instruction manual where applicable, but replace the steps indicated below with these instructions. Please check to ensure that the update has been installed.

- 1) Select the System Menu.
- 2) Touch the [Information] button.
- 3) Confirm that the information in the display indicates the version numbers as noted above.

### 1. GYA553 New firmware Version 4.x support. → Refer to T16IZ/T16IZ SUPER GYA553 V4 Setting manual

### 2. Some of the audio for “Sound Select” has been revised.

## V5.0

### 1. CGY770R support. → Refer to T16IZ/T16IZ SUPER CGY770R Setting manual

### 2. Added confirmation dialog for group setting button of condition

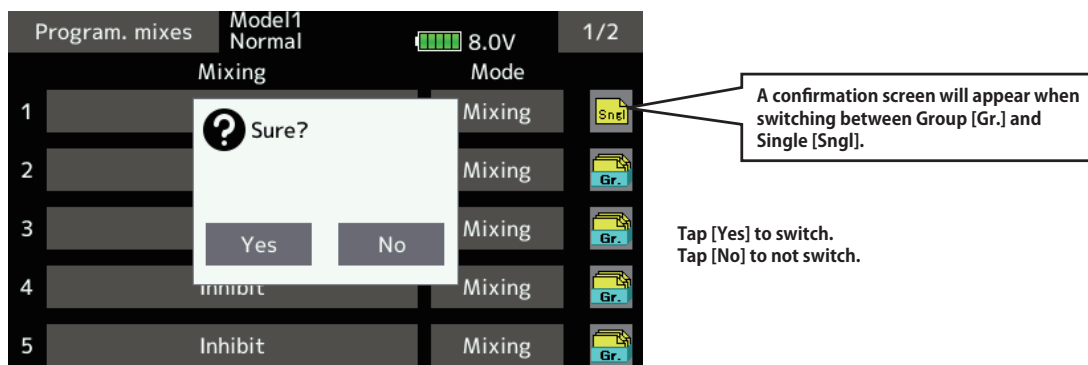

### 3. Added power off confirmation function

System menu → [H/W setting]

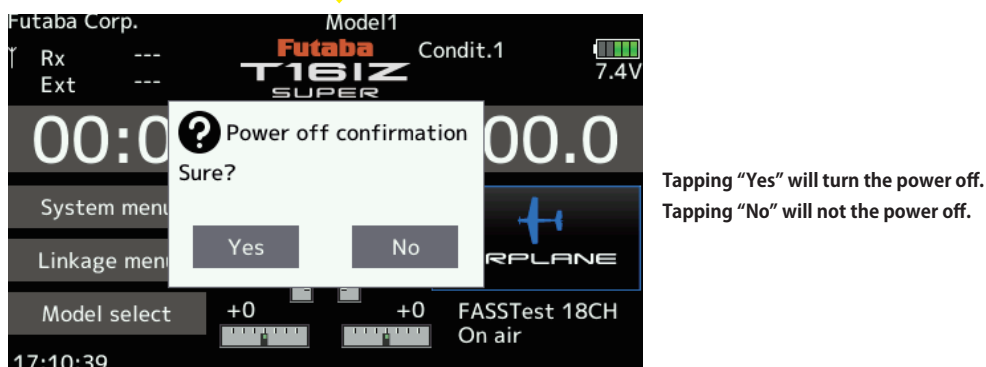
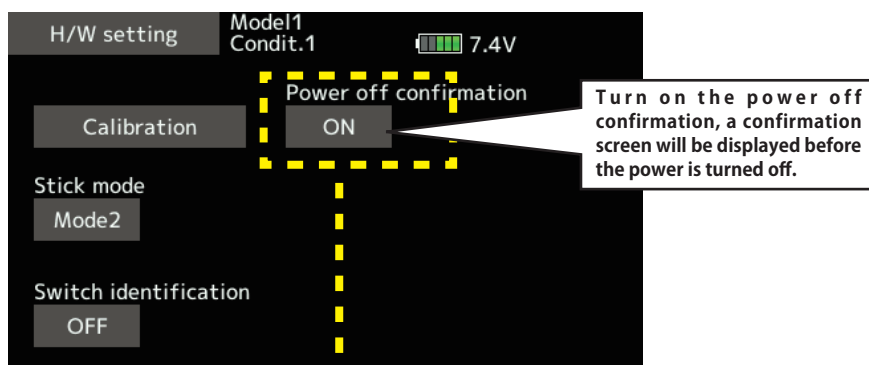

**1. Receiver setting : It is now possible to connect a compatible receiver to the S.I/F port of the transmitter and configure the receiver settings.**

Compatible receivers are as follows. (As of January 2024)

- R7208SB/R7308SB (Compatible with software version 2.0 or later)
- R7206SB/R7306SB
- R7214SB/R7314SB

① Connect the **S.BUS2 port** of the receiver and the **S.I/F port** of the transmitter with a cable.

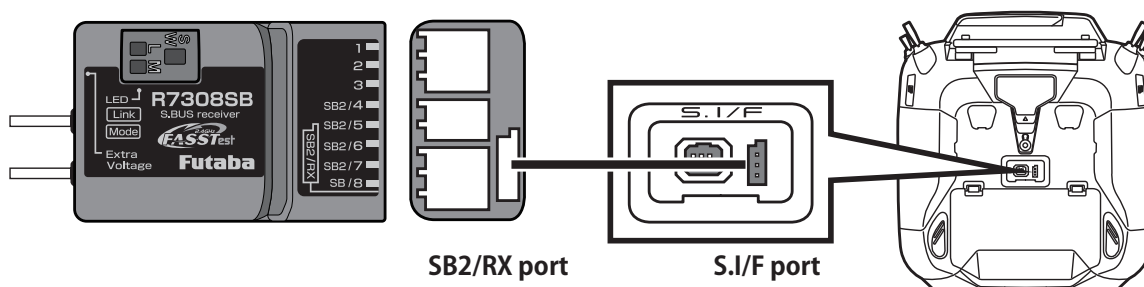

② Turn on the power switch while pressing the **U.MENU/MON** button on the transmitter.

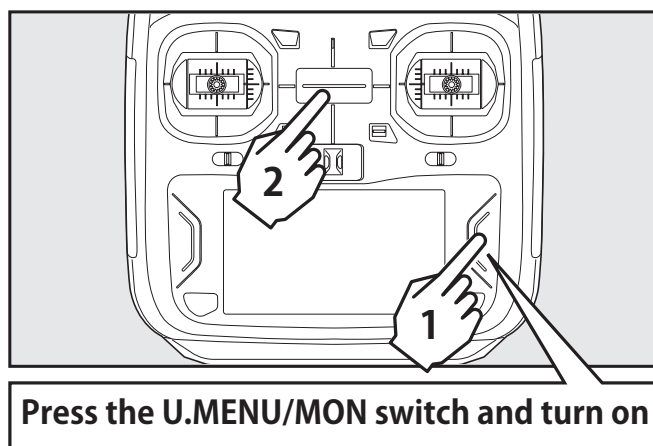

\*For safety reasons, receiver settings cannot be made while radio waves are being transmitted.

③ Tap **[Receiver setting]** on the **System menu**.

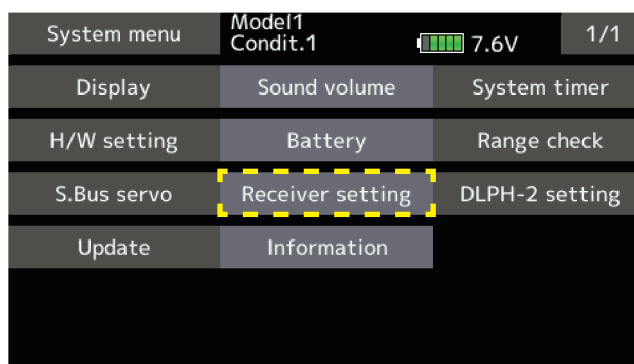

④ Tap [Read].

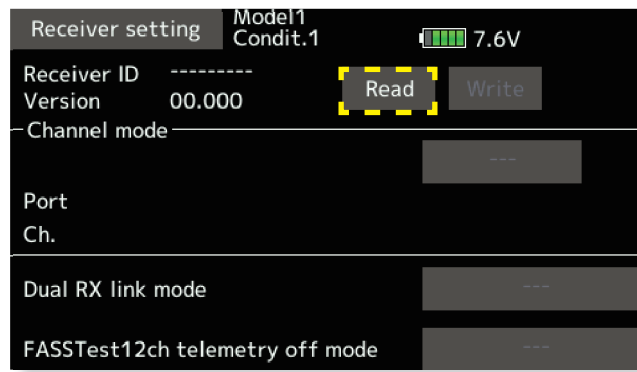

⑤ The receiver settings will be displayed. The displayed contents vary depending on the model.

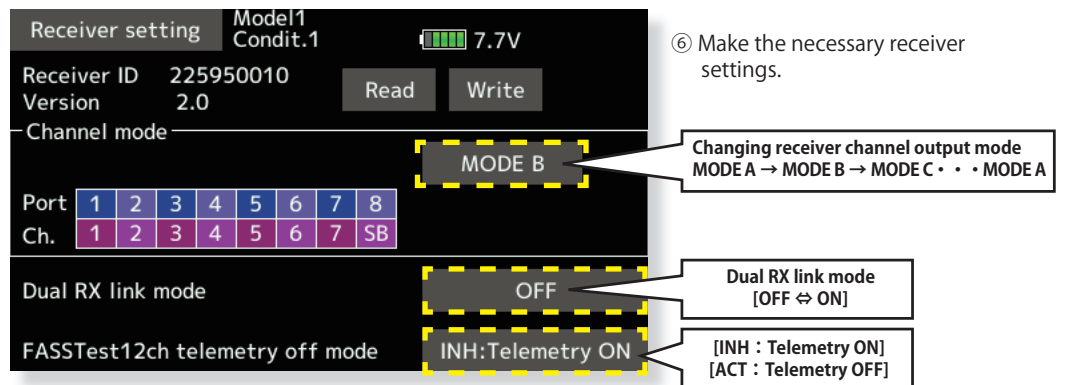

⑦ Tap [Write]. → Receiver settings will be changed.

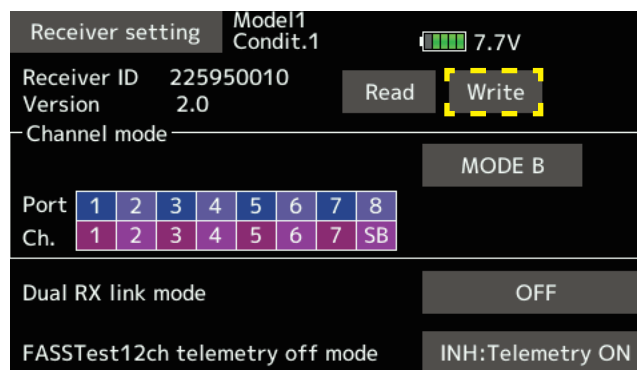

\* T16IZS cannot operate after 17ch.

⑧ Remove the receiver from the transmitter.

## 2. DLPH-2 setting : It is now possible to connect a DLPH-2 to the S.I/F port of the transmitter and configure the DLPH-2 settings.

- ① Connect the power supply to the BAT.1 or BAT.2 port of DLPH-2.
- ② Connect the **RX1 port** of the DLPH-2 and the **S.I/F port** of the transmitter with a cable.

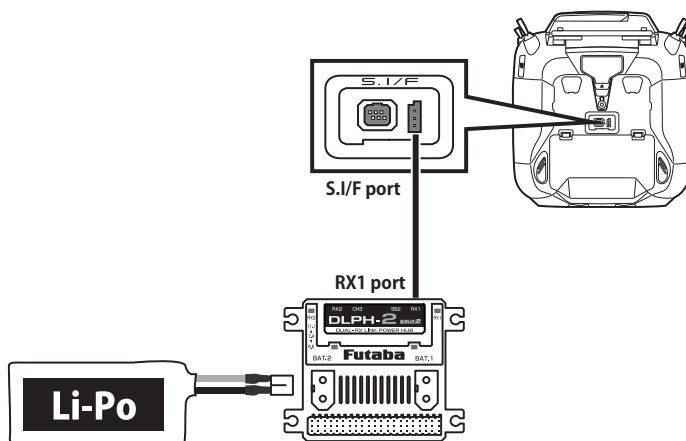

- ③ Turn on the power switch of DLPH-2.
- ④ Tap **[DLPH-2 setting]** on the **System menu**.

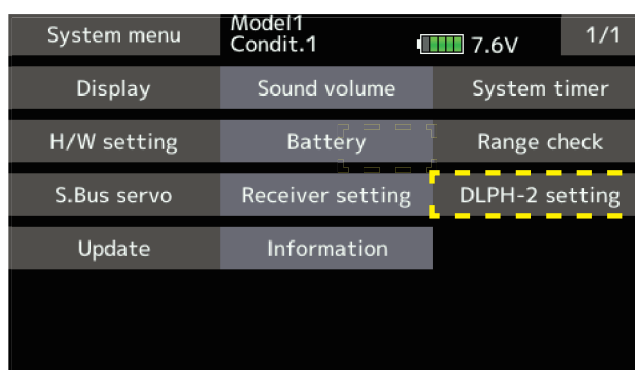

- ⑤ Tap **[Read]**.

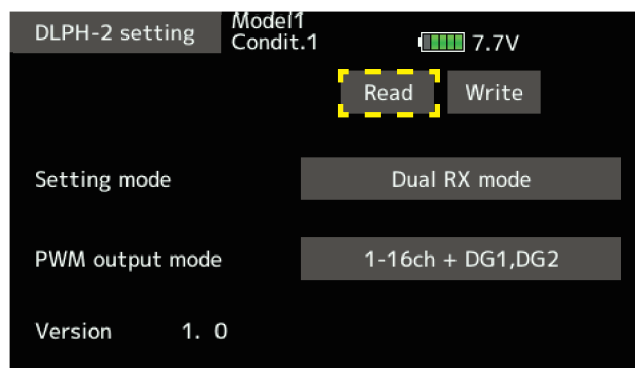

- ⑥ The DLPH-2 settings will be displayed.

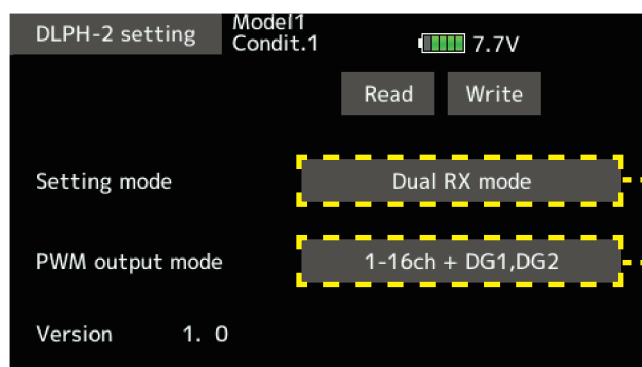

- ⑦ Configure the DLPH-2.

Dual RX mode → Single RX mode → Airplane gyro mode → Dual RX mode → ...

1-16CH + DG1,DG2 → 17-24CH + DG1,DG2 → 1-16CH + DG1,DG2 → ...

Mode selection

\*When setting mode is set to **[Airplane gyro mode]**, PWM output mode is fixed to **[1-16CH + DG1,DG2]**.

\* T16I2S cannot operate after 17ch.

⑧ Tap **[Write]**. → DLPH-2 settings will be changed.

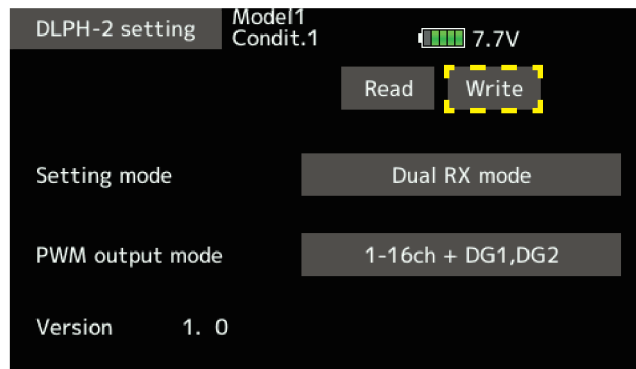

⑨ Remove DLPH-2 from the transmitter.

### 3. Added switch identification function : On the hardware selection screen, operate the desired toggle switch and it will be automatically selected.

① Tap **[H/W setting]** on the **System menu**.

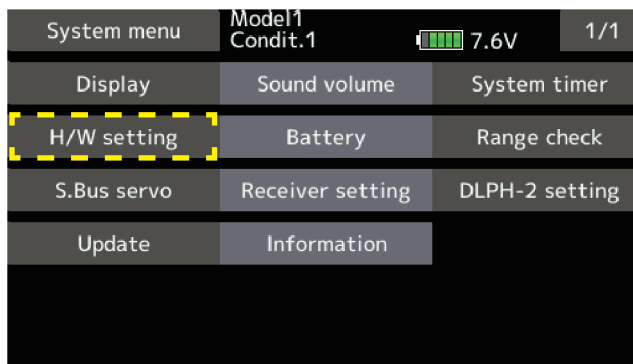

② Setting **[Switch identification]** to **[ON]** enables the switch identification function. Set to **[OFF]** to disable the switch identification function.

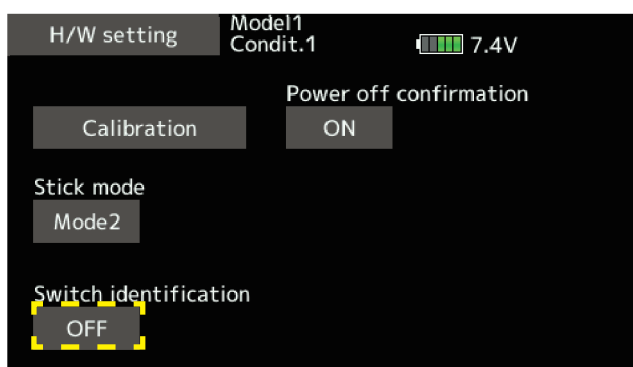

③ Call the **[Hardware select]** screen from the settings screen for each function.

④ Operate the toggle switch (either **SA to SH**) to assign.

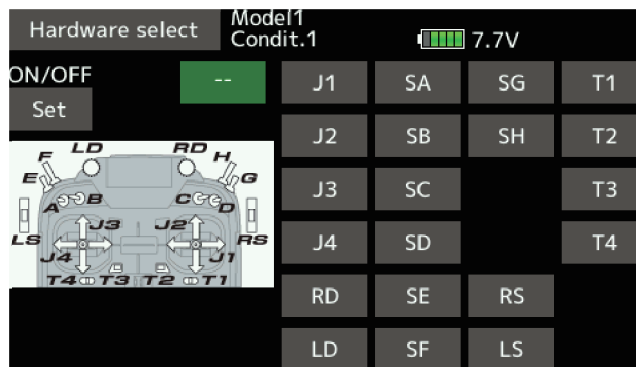
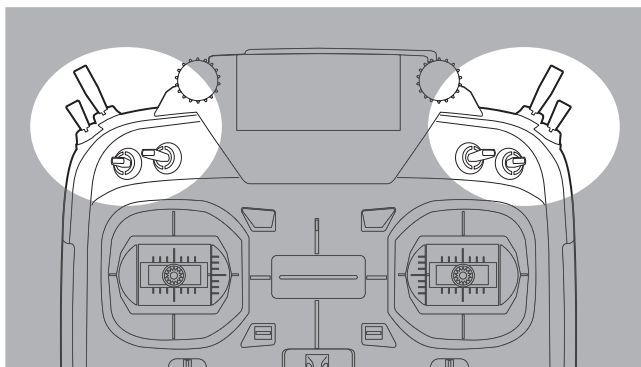

⑤ The operated switch is selected. Sets the current switch position to **ON**. Operating the switch changes the **ON** position.

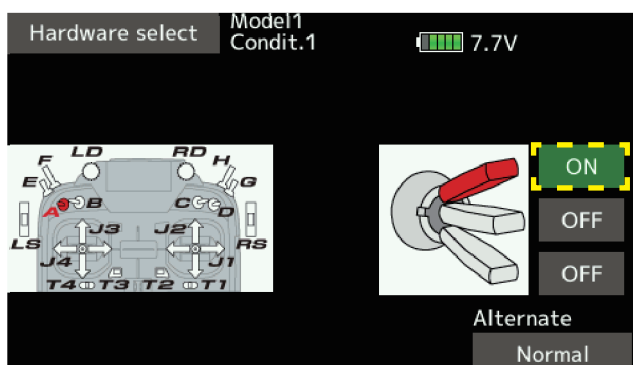



## 1. Switch Sounds : The Sound select function adds sounds to switch positions.

(Only English sounds are supported.)

- Tap the [Sound Select] button in the linkage menu to call the setup screen shown at the right.
- Take notice of the SW Letter and position
- Tap the desired switch position.

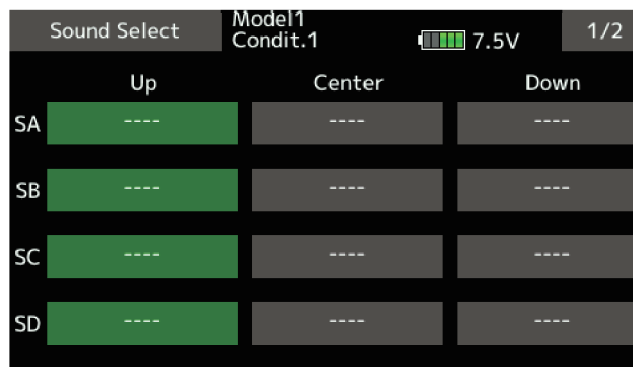

- Tap on the desired sound to add the requested sound in the previously selected switch position. (It will demo the sound once pressed)

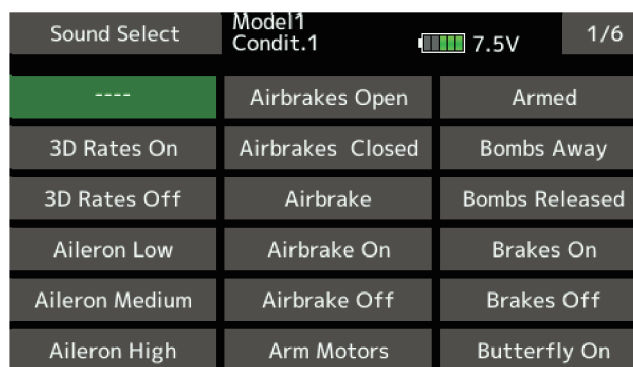

**NOTE:** Sounds and switch positions do not acknowledge condition priority.

Sounds are intended as a reference for changes in flight profile and will need to be changed manually if programming deviates from previous setup.

---

## 2. Sound notification: It is possible to notify the operating status of the transmitter by voice, such as ON/OFF of various mixing functions.

(Only English sounds are supported.)

- Tap the [Warning Setting] button in the linkage menu to call up the warning settings screen.
- Display the second page and call up the settings screen below.

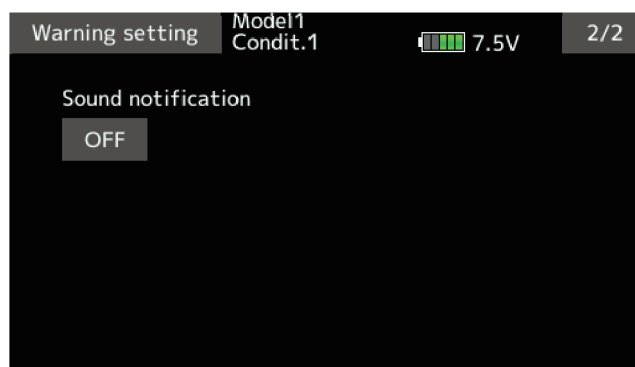

- Tap the [Sound notification] setting button to turn the sound notification function ON/OFF.
- If you set the sound notification function to ON, you will be notified by voice when the ON/OFF status or condition of various mixing functions changes.

**NOTE:** Condition audio notifications use standard condition names. Please note that if you change the condition name or rearrange the priority order, the audio notification and display will no longer match.

---

## 3. Telemetry settings: Added gear ratio setting button to Kontronik ESC and Scorpion ESC.

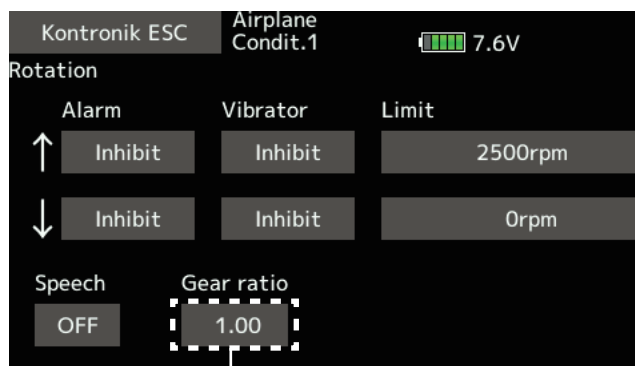

● If the gear is down, enter the gear ratio to display the helicopter rotor speed and the airplane gear down propeller speed.

---

## 4. Telemetry settings: Changed the motor pole number setting for each ESC to "100".

Previously, the number of poles was up to 36, but now it can be set up to 100.

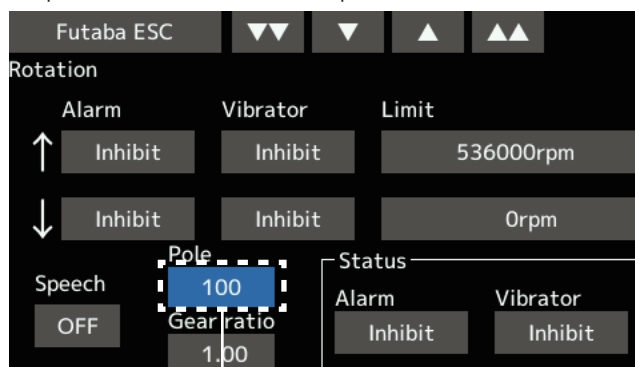

● Enter the number of poles for your motor.

## V2.1

### 1. Bug fix for European T16IZ SUPER [For Europe only]

Fixed an issue where communication became unstable when operating another transmitter at a short distance when using the T16IZ SUPER sold in the European region. This problem is ONLY when you use T16IZ SUPER under S-FHSS mode.

\*T16IZ SUPER sold outside Europe does not have the above problem. Also, T16IZ does not have the above problem.

## V2.0

### 1. Receiver or gyro updates

By connecting a receiver or gyro that supports updates to the S.I/F connector of the transmitter, it is possible to update their software.

- ① Download the update file of the update data from Futaba website.
- ② Extract the update file on your computer. The "FUTABA" folder will be created on your computer.
- ③ Copy the "FUTABA" folder into your microSD card.
- ④ Insert the microSD card with "FUTABA" folder that contained the update software into the SD card slot on your transmitter.
- ⑤ Turn on the transmitter and call "System Menu" ⇒ "Update".

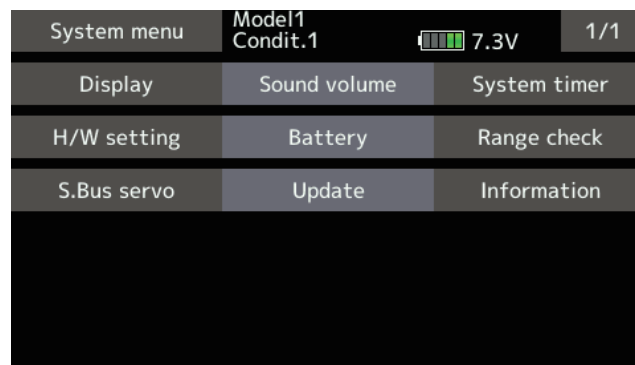

- ⑥ Select the product to update.

\*Conventional Servo Update and Sensor Update screens open from this screen.

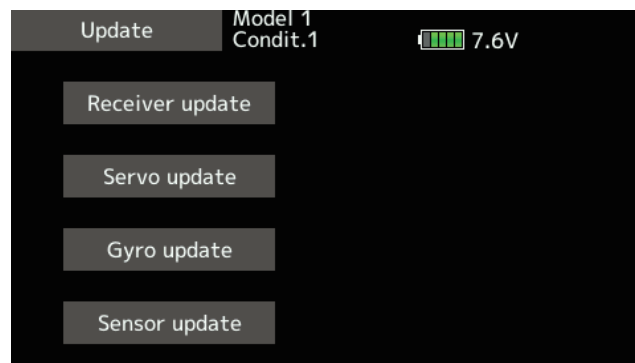

- ⑦ Select the product name to update.

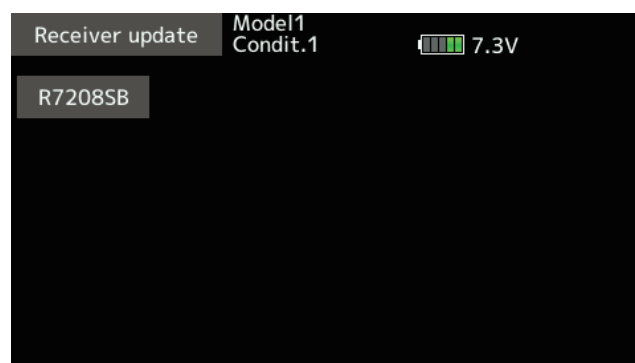

- ⑧ The update screen is displayed. Connect the receiver or gyro to be updated to the S.I/F connector of the transmitter, prepare for update, and then tap the [Update] button.

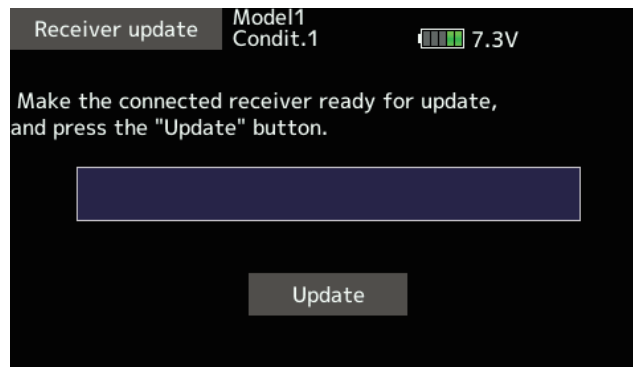

- ⑨ Update start.

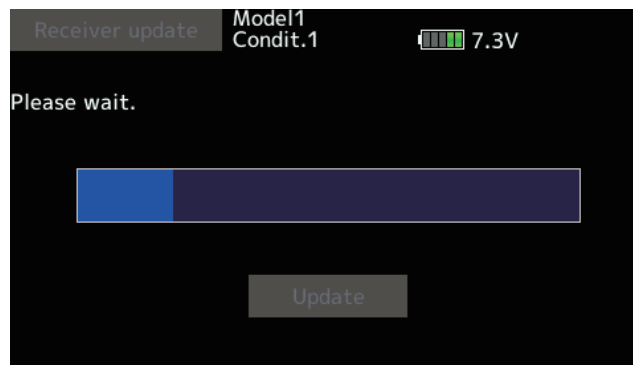

- ⑩ When finished, the following will appear.

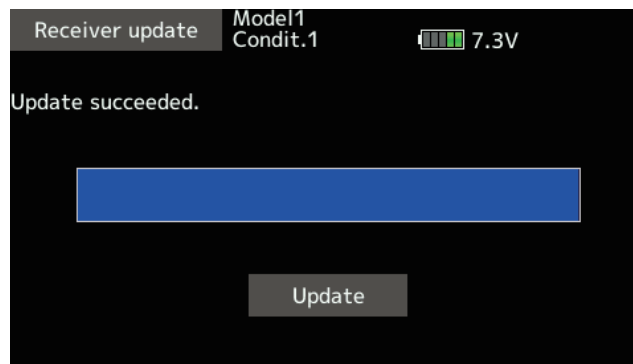

- ⑪ Disconnect the receiver or gyro from the transmitter's S.I/F connector.

V1.2

## 1. GYA553 New firmware Version 3.x support. → Refer to T16IZ/T16IZ SUPER GYA553 V3 Setting manual

Airplane Gyro GYA553 is compatible with 3rd aileron and 4th aileron.